

TIMBER-CONCRETE COMPOSITE – A CONTRIBUTION TO IMPROVED SUSTAINABILITY IN CIVIL ENGINEERING

Klaus Holschemacher

Leipzig University of Applied Sciences (HTWK Leipzig), Structural Concrete Institute, Karl-Liebknecht-Str. 132, Leipzig 04277, Germany

Abstract

Timber-concrete composite (TCC) members consist of timber beams connected with a reinforced concrete slab by specialized shear connectors providing the bond between the timber and the concrete shares of the composite section. Main TCC applications are floor systems, either for reconstruction of existing timber beam ceilings or for construction of new buildings. The paper reports the basic design requests according to next generation of Eurocodes and recent developments in TCC. Particular attention is paid to the various design opportunities for the concrete slab in TCC members. TCC is a valuable compromise regarding load-bearing capacity, fire resistance and sustainability issues in comparison to ordinary reinforced concrete slabs. Based on their improved sustainability, it is to expect that the application of TCC will strongly increase in future construction practice.

Keywords: *timber-concrete composite, flexible bond, shear connectors, sustainability*

1. INTRODUCTION

Timber and concrete are construction materials with considerably different properties. Timber is a renewable material with relative high compression strength, tensile strength, and modulus of elasticity in parallel to the fibre direction, whereas in lateral direction these mechanical properties are significantly less favourable. A serious disadvantage of timber is its flammability and sensitivity against moisture and biological pests. In contrast to timber, concrete is characterized by its outstandingly high compressive strength combined with low tensile strength. It is generally accepted that concrete is a building material with very good price to compressive strength ratio. To compensate the low concrete tensile strength, usually the members' tensile zone must be reinforced, e.g. with steel bars or steel meshes. This creates a new structural material, called reinforced concrete (RC), with wide and manifold usage in construction practice. An essential benefit of concrete as well as reinforced concrete is their non-flammability and high fire resistance.

The main idea of timber-concrete composite (TCC) is the combination of timber and concrete in composite members in a way where the advantageous properties of both building materials may be optimally used. Realization of this demand succeeds very impressive in the construction of TCC slabs, because the concrete slab is mainly under compressive stresses, while the timber beams predominantly bear tensile stresses. In comparison to RC slabs, the environmental impact of TCC slab is strongly reduced. Furthermore, the fire resistance of TCC slabs is better than that for comparable timber beam ceilings (Holschemacher & Kieslich 2021).

Based on the mentioned properties it is to expect that TCC will capture a remarkable share of floor systems in construction of new as well as strengthening and revaluation of existing buildings. The state-of-the-art of TCC is summarized in the following sections.

2. OVERVIEW ABOUT HISTORY OF TCC

First reports on TCC trace back to the early 20th century. The combination of timber and concrete in a composite member was mainly motivated by scarcity of building materials. Patents by Müller in the year 1922 and Schaub in the year 1939 (Figure 1) demonstrate the knowledge on TCC at this time (Schaub 1939). It is interesting but hardly known that a considerable number of TCC bridges was erected in the USA in the 1930s to 1940s (Wacker, Dias & Hosteng 2017).

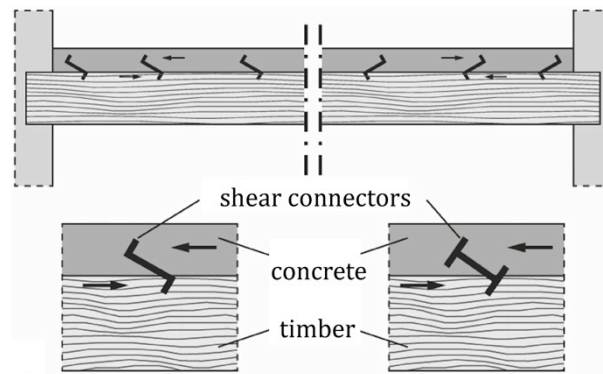

Fig. 1. TCC patent by Schaub (Schaub 1939).

Starting from the 1950s, TCC was used for strengthening of timber beam ceilings in many countries. Mostly, the strengthening requirements have been based on the fact that timber beam ceilings often were constructed without a design considering serviceability demands in past times. Therefore, the flexural stiffness and deformations as well as vibration sensitivity of timber beam ceilings were often insufficient. In this context, the arrangement of a concrete slab in bond with the existing timber beam ceiling quickly developed to an adequate and economic strengthening technique.

For new construction, TCC was rather a niche product in past. Main reason is the insufficient normative situation, because there is only little information on TCC in the existing codes until now. Nevertheless, situation is strongly changing for about 10 years, encouraged by the increasing importance of sustainability issues in civil engineering. Nowadays, TCC is a competitive building method with many pioneering project examples (Holschemacher & Kieslich 2021).

3. STRUCTURAL BEHAVIOUR

3.1. General structure of TCC

The main components of TCC members are timber beams, concrete slab and shear connectors. The beams, in general referred as timber beams, may consist of coniferous wood or glued laminated timber, only in few cases hardwood was used. Timber beams may be arranged with spacing between them resulting in a T-beam-like structure or without any spacing as board stack elements. For spaced timber beams it is also possible to arrange the concrete slab between the timber beams. Sometimes, there is a boarding or other non load-bearing layer between the timber beams and the concrete slab, e.g. in case of strengthening of existing timber beam ceilings, Figure 2.

Most important part of TCC systems is the shear connection between timber beams and concrete slab. Shear connectors have to bear shear and tensile forces and must be easy installable at the site. Over the years many different systems were developed. Basically, they can be classified in dowel type steel fasteners (screws, nails, bolts etc.), notches, and combinations of them. Besides, special connector types like friction based systems or steel wire meshes glued in a prepared slit of the timber beam are used in practice, sometimes. Rather less usual in construction practice are directly glued connections between the concrete and the timber part of the composite section (Holschemacher 2021).

Steel fasteners may be arranged in vertical or inclined position at the top or the side of the timber beams (Berardinucci et al. 2019). Inclination can be in both-way or one-way direction. In case of a one-way inclination of the fasteners it must be taken care that the direction of inclination is corresponding to the tensile stress trajectories.

It is often useful to vary the spacing of the shear connectors along the timber beam axis in accordance to the shear distribution resulting in a concentration of shear connectors near to support. To avoid very low spacing, it is possible to arrange steel fasteners in two rows. For some typical arrangements of shear connectors see Figure 3.

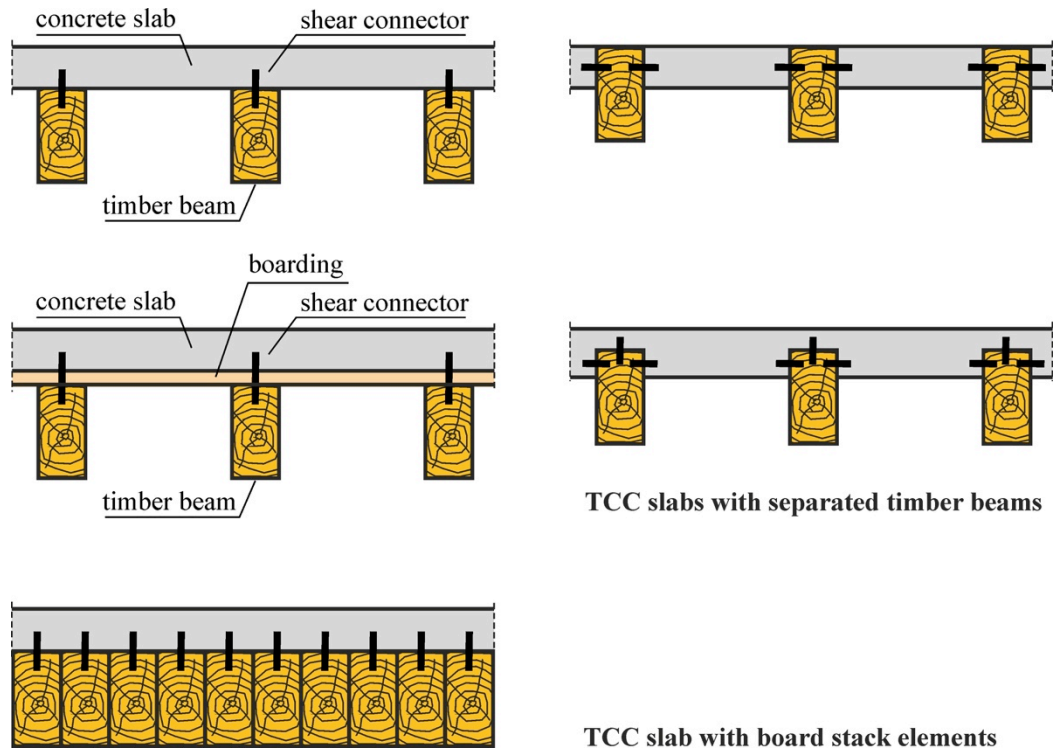

Fig. 2. General structure of TCC slabs.

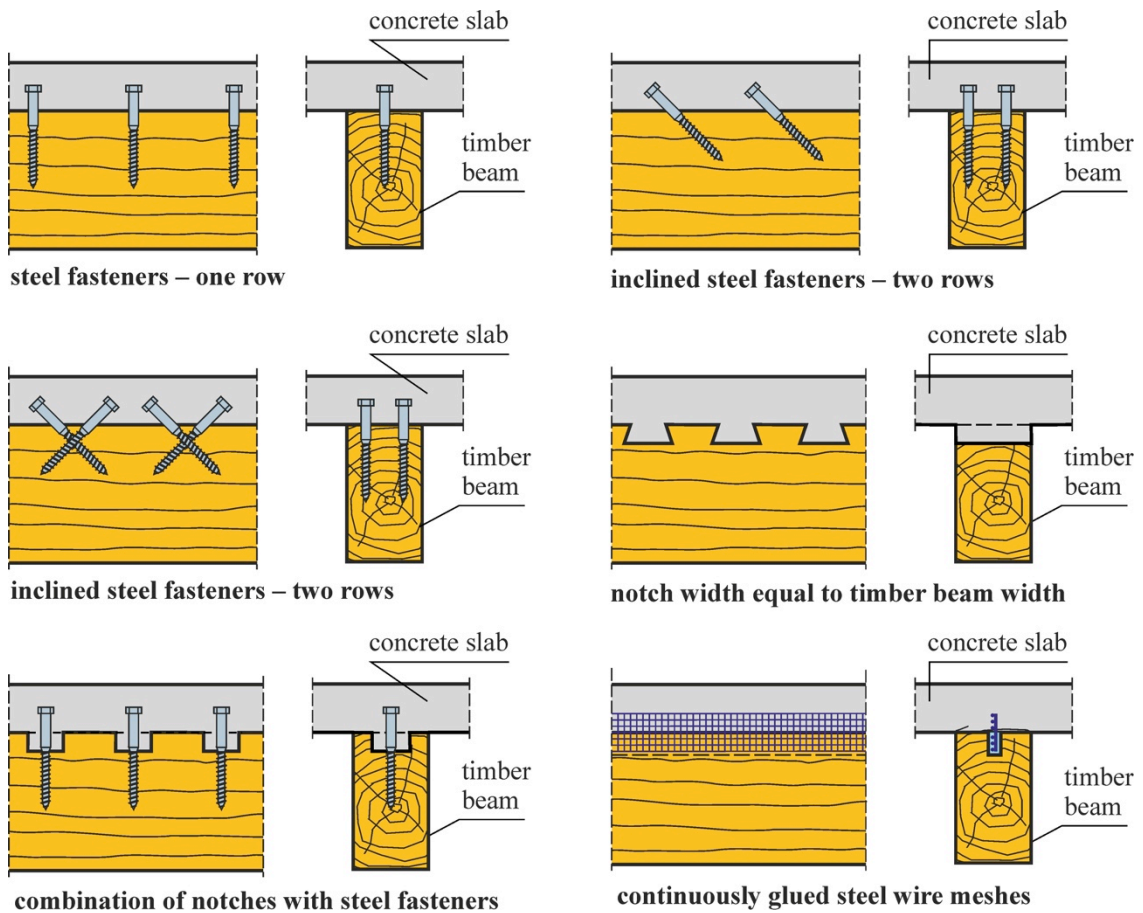

Fig. 3. Arrangement of shear connectors in TCC slabs.

3.2. Flexible bond and bending stiffness

Dimensions and mechanical properties of the timber beams and the concrete slab as well as spacing and mechanical properties of the applied shear connectors influence the bending stiffness of TCC slabs. When using steel fasteners, notches or a combination of them as shear connectors, only flexible bond in the interface between concrete and timber is achievable (Holschemacher 2021). It means that there is a slip between the bottom side of the concrete slab and the top of the timber beams. Main reason is the flexural deformation of the shear connector that will increase in case of a not load-bearing interlayer (e.g. boarding) between the slab and the beams. The difference in the strain distribution for sections without bond, flexible bond and rigid bond is shown for the serviceability limit state with linear stress-strain relationships for concrete and timber in Figure 4.

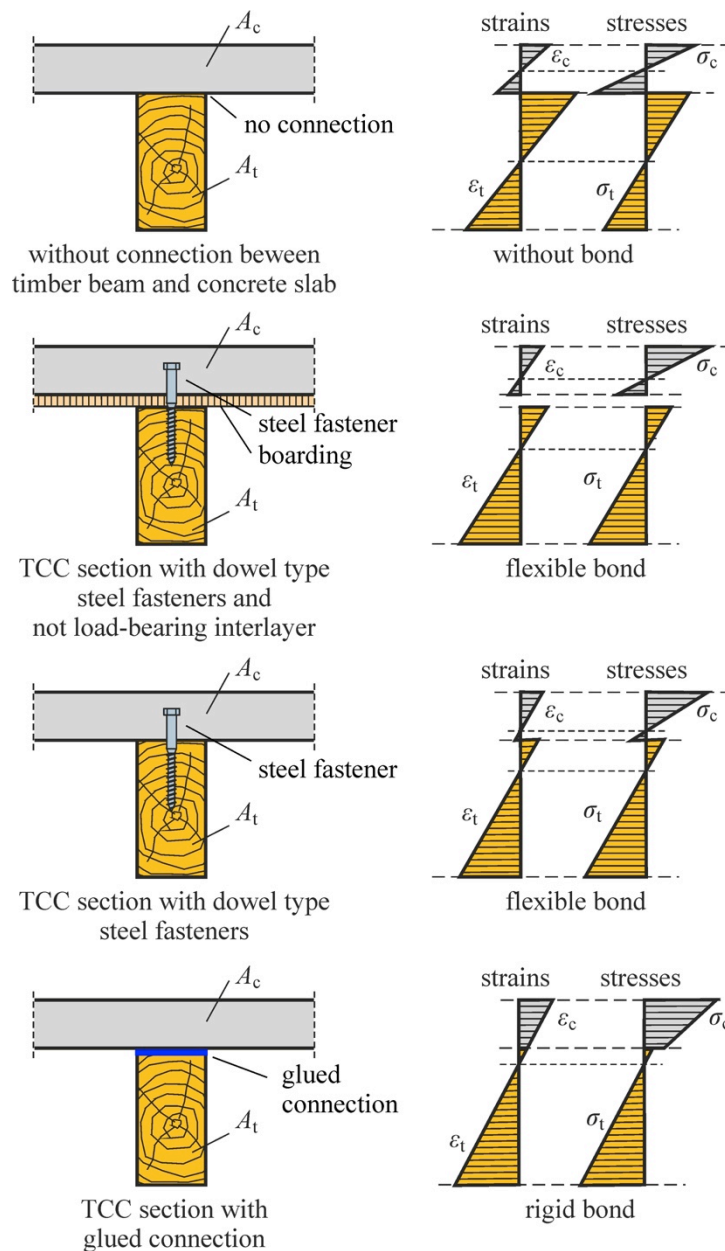

Fig. 4. Stress and strain distribution in sections without bond, flexible bond, and rigid bond.

Knowledge on the effect of the various influence parameters on bending stiffness of TCC slabs is crucial for the design of such members. Therefore an example was prepared considering the usual range of mechanical properties and dimensions of beams, slab, and shear connectors, see Figure 5. It is obvious that the heights of the concrete slab and of the timber beams are most influential. But, all other parameters like stiffness of the shear connectors, timber strength class, and concrete strength class must be additionally considered when designing TCC members. In case of strengthening existing timber beam ceilings, the design options are limited on the selection of concrete strength class, concrete density, and shear connectors. When new structures are erected, additionally the most appropriate timber type may be chosen, e.g. glued laminated timber.

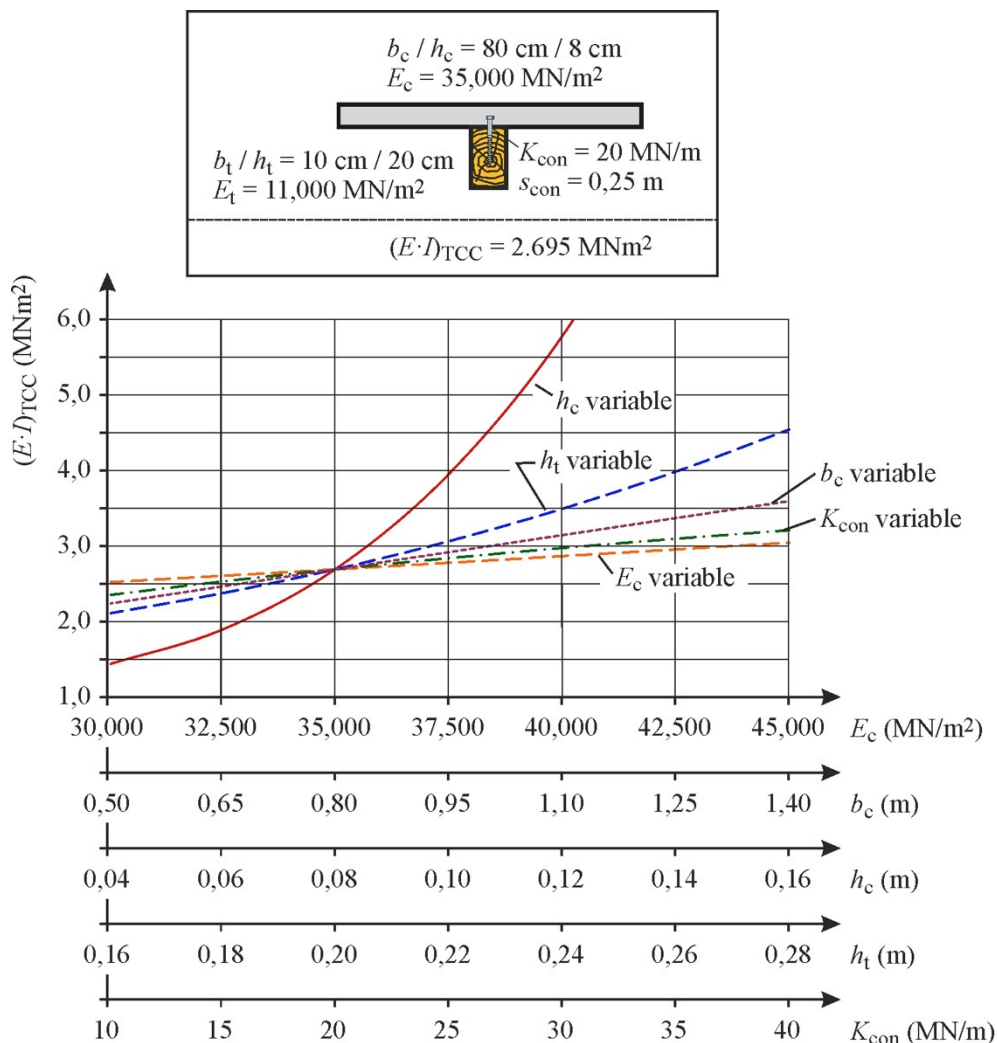

Fig. 5. Influence parameters on bending stiffness.

4. DESIGN OF TCC SLABS

4.1. Normative regulations for shear connectors

At time, TCC members may be calculated in accordance with the provisions in EN 1995-1-1 (2004), Annex B, at the basis of the so-called γ -method. Required mechanical properties of concrete and timber may be taken from EN 1992-1-1 (2004), respectively EN 1995-1-1 (2004). For the needed mechanical properties of the shear connector, e.g. stiffness and ultimate load, there are no normative regulations available, neither in DIN EN 1992-1-1 (2004) nor in EN 1995-1-1 (2004). Therefore, these mechanical properties must be defined in a European Technical Assessment or National Technical

Approval. At present, more than 20 Technical Approvals for the application of shear connectors in TCC are practicable (Holschemacher & Kieslich 2021).

If it is intended to apply shear connectors without valid Technical Approval or outside of their scope, it is unavoidable to carry-out experiments for the determination of all required mechanical properties. Usually, push-out tests are an accepted test set-up in this context.

The current lack of normative regulations for shear connectors is a serious disadvantage for the TCC method. This situation will change with the next generation of Eurocodes, see CEN /TS 19103:2021 (2021). Among others, there is formulated a design proposal for metallic fasteners, bolts, screws, and nails without pre-drilling:

$$K_{\text{ser}} = (2 \cdot \rho_m^{1.5} \cdot d) / 23 \quad (1)$$

and for nails with pre-drilling:

$$K_{\text{ser}} = (2 \cdot \rho_m^{1.5} \cdot d^{0.8}) / 30 \quad (2)$$

where K_{ser} = stiffness of shear connector in the serviceability limit states; ρ_m = mean value of timber density in kg/m^3 ; and d = diameter of the shear connector in mm. The application of these verifications will substantially simplify the future design procedure for TCC slabs.

4.2. Concrete

There are different reasons for tensile stresses in the concrete slab of TCC systems. Basically, it cannot be ruled out that they exceed the concrete tensile strength. Therefore, it is to discuss if reinforcement in the concrete tensile zone is necessary.

In longitudinal direction of single span TCC systems, the concrete slab is predominant under compression. However, at the bottom side of the concrete slab, there is a small tension zone in most cases, see Figure 4. Because the height of the tensile zone measures only few millimetres or centimetres, the arrangement of steel bar or mesh reinforcement is not expedient, see Figure 6a. There is a low tensile strain or even compressive strain in the reinforcement making it completely or almost impossible to bear tensile forces if concrete tensile zone is cracking.

There are various other possibilities for verification (Figure 6b – 6d):

- determination of inner forces for the concrete slab and verification as plain concrete section
- consideration of the concrete tensile zone as not load-bearing layer
- application of fibre reinforced concrete.

Verification as plain concrete section is based on EN 1992-1-1 (2004), Chapter 12.6. The design value of the resistant axial force N_{Rd} is limited in dependence on the e/h ratio, where e = eccentricity and h = height of the concrete slab. For calculation of the design value of compressive strength f_{cd} , the coefficient α_{cc} is needed. It must be respected that the coefficient α_{cc} is defined at lower value for plain concrete in comparison to reinforced concrete in some National Annexes to EN 1995-1-1, e.g. in Germany. Sometimes, the stress verification $\sigma_{\text{ct}} \leq f_{\text{ct}}$ is preferred in design practice, but it is not covered by EN 1995-1-1 rules.

The consideration of the concrete tensile as a not load-bearing layer is another option for verification (Dias, Schänzlin & Dietsch 2018). However, it results in an iterative design procedure. Furthermore, it is not clear how to deal with the shear stiffness of the shear connectors. Usually, the shear stiffness is dependent on the thickness of the not load-bearing interlayer. But in case of a not load-bearing concrete tensile zone, the presence of concrete will reduce the deformation of shear connectors and, therefore the reduction of shear stiffness will not have the same extend like in a boarding.

Finally, the application of fibre reinforced concrete, especially steel fibre reinforced concrete (SFRC) is recommended. In SFRC-sections, the bending tensile strength may be activated over the full height of the tensile zone. Verification is possible by comparison of concrete tensile strength σ_{ct} with the ultimate residual tensile strength of SFRC $f_{\text{ctd,L2}}^{\text{f}}$.

It must be stated that there are many other reasons for tensile stresses in the concrete slab of TCC slabs, especially in perpendicular direction to the timber beam axis (Kieslich & Holschemacher 2013). Therefore, complete omission of reinforcement is not impossible but will be an exemption in construction practice.

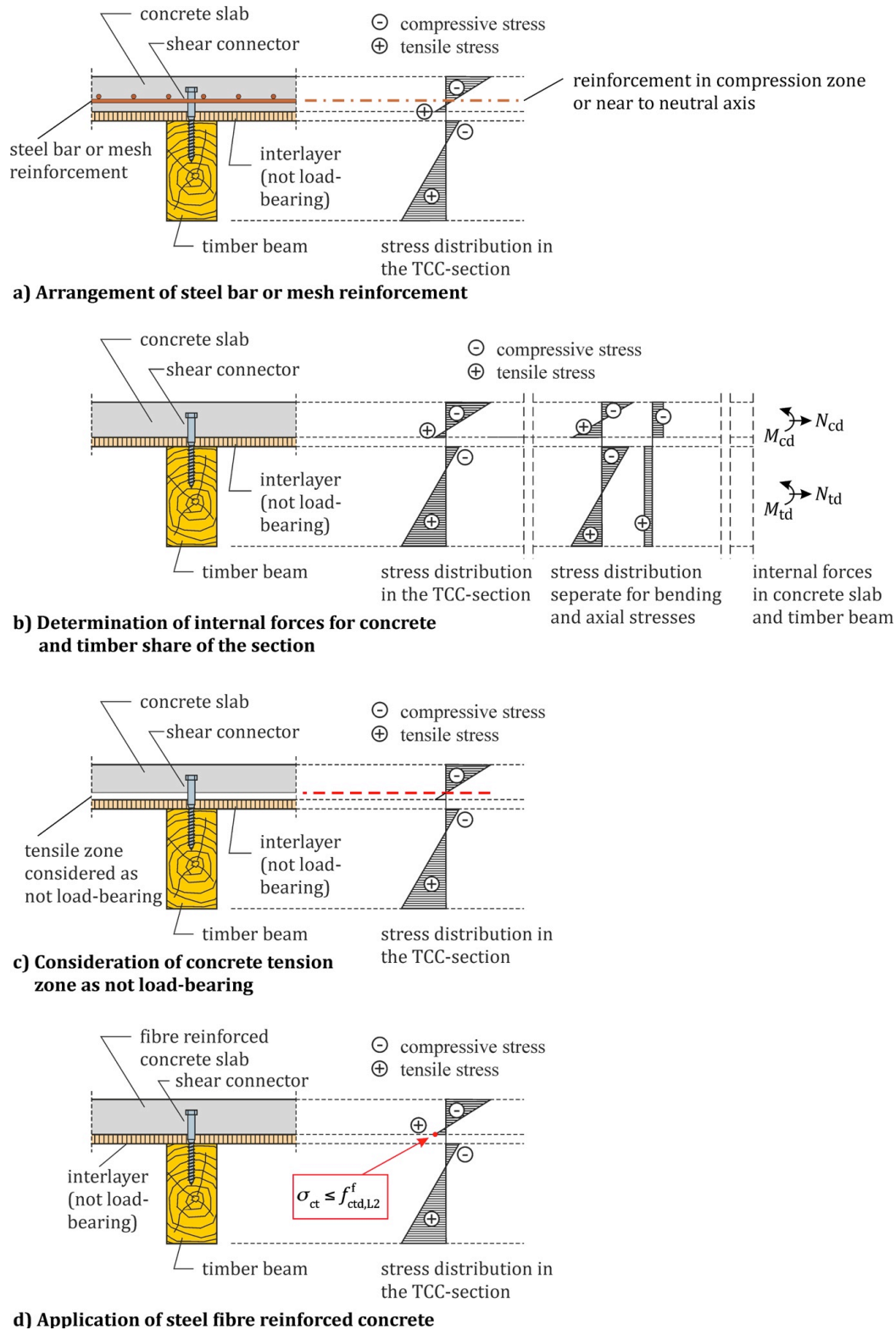

Fig. 6. Verification of concrete tensile stresses.

5. APPLICATIONS

5.1. Strengthening of existing timber beam ceilings

TCC is an acknowledged technology for strengthening of existing timber beam ceilings. In many cases are not the ultimate limit states but the serviceability limit states the problem of older timber beam ceilings. Especially, large deformations and vibration sensitivity are to state in this context. By the additional arrangement of a concrete slab in flexible bond to the timber beams these problems may easily be solved. It is to mention that the bottom side of the timber beam ceilings in most situations may be unchanged. This is an invaluable advantage when reconstructing buildings belonging to the cultural heritage. Moreover, the fire protection of TCC slabs is much better than of timber beam ceilings before strengthening (Buchanan & Abu 2017). An adequate fire resistance class is generally achievable resulting in big benefits for public buildings like museums or theatres (Holschemacher & Quapp 2019), (Quapp & Holschemacher 2020).

5.2. TCC in construction of new buildings

Nowadays, sustainability issues are of strongly increasing importance in civil engineering. Therefore, after years of stagnation, there is a revival of TCC in construction of new buildings. It was proved by recent investigations that the global warming potential of TCC slabs is approximately 30% reduced in comparison to comparable reinforced concrete slabs (Holschemacher, Hoffmann & Heiden 2021), (Hoffmann, Heiden & Holschemacher 2021). This may be the main reason for rising application of TCC in new erected structures.

6. SUMMARY

Load-bearing behaviour of TCC-slabs is mainly influenced by the geometry and mechanical properties of concrete slab, timber beams and shear connectors. In usual TCC slabs the concrete is predominantly under compression but a little tensile zone may not be avoided. Because of the location of the common steel bar or mesh reinforcement near to neutral axis, this reinforcement cannot bear the tensile forces after cracking of concrete. Therefore, other verifications are recommended, e.g. on basis of internal forces as plain concrete or application of SFRC.

Nowadays, TCC is a proved building method with strongly increasing application in construction practice, both for strengthening of existing timber beam ceilings and for construction of new structures. The advantageously reduced environmental impact and new prefabrication techniques will strengthen this tendency.

REFERENCES

1. Holschemacher, K & Kieslich, H 2021, 'Timber-concrete composite' (in German), in K Bergmeister, F Fingerloos & JD Wörner (eds.), *Betonkalender 2021*, Berlin, Ernst & Sohn, <https://doi.org/10.1002/9783433610206.ch4>.
2. Schaub, O 1939, 'Verbunddecken aus Holzrippen und Betonplatte', German Patent, Reichspatent DE673556C.
3. Wacker, K, Dias, A & Hosteng, T 2017, 'Investigation of Early-Timber-Concrete Composite Bridges in the United States', *Conference Proceedings, 3rd International Conference on Timber Bridges*, Skelleftea, Sweden.
4. Holschemacher, K 2021, 'Timber-concrete composite – a high-efficient and sustainable construction method' *Proceedings of International Structural Engineering and Construction*, Vol. 8 (2021), 1, doi:10.14455/ISEC.2021.8(1).STR-59.
5. Berardinucci, B, Di Nino, S, Gregori, A & Fragiaco M 2019, 'Mechanical Behavior of timber-concrete connections with inclined screws'. *International Journal of Computational Mechanics and Experimental Measurements* 5(6): 807-820.

6. EN 1992-1-1 (2004), *Eurocode 2: Design of Concrete Structures – Part 1-1: General – Common rules and rules for buildings*, European Committee for Standardization.
7. EN 1995-1-1 (2004). *Eurocode 5: Design of Timber Structures – Part 1-1: General – Common rules and rules for buildings*, European Committee for Standardization.
8. CEN/TS 19103:2021 (2021). *Eurocode 5: Design of Timber Structures – Structural design of timber-concrete composite structures – Common rules and rules for buildings*, European Committee for Standardization.
9. Dias, A, Schänzlin, J & Dietsch, P 2018, ‘*Design of timber-concrete composite structures*’, State-of-the-art report by COST Action FP1402 / WG 4. Shaker, Germany.
10. Kieslich, H & Holschemacher, K 2013, ‘Lateral Load Bearing Behavior of Timber-Concrete Composite Constructions’, *Advanced Materials Research*, Vol. 778, 665-672, doi: 10.4028/www.scientific.net/AMR.778.665
11. Buchanan, A & Abu A 2017, *Structural design for fire safety*. Wiley, 2017.
12. Holschemacher, K & Quapp, U 2019, Revaluation of Historical Buildings with Timber-Concrete Composite in Compliance with Fire Resistance Demands. In R Aguilar, D Torrealva, S Moreira, MA Pando & LF Ramos (eds): *Structural Analysis of Historical Constructions*. RILEM Bookseries, Vol. 18. Springer, Cham, doi: 10.1007/978-3-319-99441-3_183.
13. Quapp, U & Holschemacher, K 2020, Heritage Protection Regulations in Germany and their Relations to Fire Safety Demands. *IOP Conf. Series: Materials Science and Engineering* 753 (2020) 042036, doi: 10.1088/1757-899X/753/4/042036.
14. Holschemacher, K, Hoffmann, L & Heiden, B 2021 ‘Environmental impact of timber-concrete composite slabs in comparison to other floor systems’ *Proceedings of the World Conference on Timber Engineering (WCTE 2021)*, Santiago de Chile, Chile. ISBN 978-1-713-84097-8.
15. Hoffmann, L, Heiden, B & Holschemacher, K 2021, ‘LCA comparison at component level’ (in German), *Bautechnik* 98, 2021. doi: 10.1002/bate.202000087.